

FLEX

PHARMACEUTICAL TABLET COATERS



IMA  **THOMAS**
Solid Dose Solutions

FLEX SERIES

THOMAS PROCESSING DRIVES INNOVATION IN THE TABLET COATING INDUSTRY WITH THE VISION TO IMPROVE OUR CUSTOMERS' COMPETITIVE ADVANTAGE BY PROVIDING THE MOST TECHNOLOGICALLY ADVANCED EQUIPMENT.



FLEX 05

The FLEX 05 benchtop tablet coater is more than just a film coater. It is a practical and highly functional coating platform for most processes including those where high weight gain, drug layers, and modified release coatings are essential.

The FLEX 05 coater includes computer-based controls with data acquisition in a compact package featuring a color touch screen HMI. Convenient and versatile, the FLEX 05 is sure to become your indispensable coater for rapid product development, feasibility studies and production of early stage clinical supplies.



FLEX 100

The FLEX 100 is a fully integrated, recipe driven R&D pilot scale tablet coating system with exchangeable drums. Designed to offer a wide variety of industry leading high-performance features, the FLEX 100 features external gun positioning, auto-unload, patented Thomas Spray Bar with Schlick patented ABC technology and 6 exchangeable drums allowing for capacity range of 2-125 Liters. The Flex 100 also comes with Wash-In-Place configurations and an optional containment version for use with highly potent products.



FLEX 200

The FLEX 200 is a recipe driven, recipe driven pilot or production scale tablet coating system with exchangeable drums. Designed to offer a wide variety of industry leading high-performance features, the FLEX 200 features external gun positioning, auto unload, patented Thomas Spray Bar with Schlick ABC technology, and exchangeable drums allowing for capacity range of 30-325 Liters. The FLEX 200 also comes available with Wash-In-Place configurations and an optional containment version for use with highly potent products.



FLEX 500

The FLEX 500 is a highly efficient tablet coating system designed for the special needs of the pharmaceutical industry, which features our patented exchangeable drum design. Machine capacity range of 40 – 920 Liters. Standard configuration allows for all aqueous tablet coating processes including film, sugar, functional, and active multi-layer coatings. Optional features allow for organic solvent coating and various OEB containment levels for potent compound processing.

THOMAS SPRAY BAR (TSB)

THE PATENTED THOMAS SPRAY BAR (TSB) IS A MODULAR SPRAY MANIFOLD. THE NUMBER OF SPRAY GUNS CAN EASILY BE ADJUSTED BY ADDING OR REMOVING SPRAY BAR SECTIONS.

The modular design eliminates the need for multiple complete spray manifolds. The TSB is designed to eliminate unnecessary parts from the process airflow path, reducing turbulence and improving spray performance. The solution and compressed air lines inside of the spray bar eliminate tablet entrapment areas and create a smooth profile. In the rare event of a clogged spray gun, the fluid nozzle can be removed and cleaned from the gun while the bar is primed and solution is in recirculation. Clearing a spray gun clog takes less than 10 minutes.

All Thomas tablet coating systems feature the TSB. The solution delivery system is engineered to deliver a consistently better performance compared to conventional manifolds, resulting in easily validated, repeatable tablet coating processes.



THOMAS ACCELA SPRAY PRO

- A PERISTALTIC PUMP WITH VFD CONTROLLER
- SOLUTION AND PNEUMATIC LINES AND FITTINGS
- SOLUTION RECIRCULATION SYSTEM
- INDEPENDENT PNEUMATIC CONTROLS FOR ATOMIZING, PATTERN, AND TRIGGER AIR
- SOLUTION TOTALIZER SYSTEM
- VOLUMETRIC OR MASS FLOWMETER FOR SOLUTION FLOW RATE CONTROL





THOMAS SPRAY BAR (TSB) PARTS CART

- DESIGNED DELRIN TRAYS TO HOLD INDIVIDUAL PARTS
- CAPABLE OF HOLDING FULLY ASSEMBLED BAR SECTIONS
- PREVENTS PARTS FROM TOUCHING TO REDUCE DAMAGE
- PROVIDES OPERATORS WITH A WORKSTATION FOR ASSEMBLY AND DISASSEMBLY
- ELIMINATES DOWNTIME AND PART-SEARCHING

QUICK DISASSEMBLY AND EFFICIENT CLEANABILITY

- TOOLLESS ASSEMBLY FOR QUICK CHANGEOVER
- INDEXABLE MOUNTING HARDWARE FOR REPEATABLE POSITIONING
- SANITARY TRI-CLAMP SOLUTION FEED AND RECIRCULATION CONNECTIONS
- SCHLICK SPRAY GUN COMPONENTS
- INDEPENDENT PATTERN AND ATOMIZING AIR CONTROL
- TSB MADE OF FDA APPROVED PEEK THERMOPLASTIC



- A streamlined sanitary design
- Easy cleanability and minimum downtime
- Efficient product changeovers
- Lightweight sections for easy handling
- Hardware that meets GMP requirements
- Innovative external gun positioning

CONTROL SYSTEMS



OPERATOR INTERFACE AND EQUIPMENT MANAGEMENT

FLEX SERIES is equipped with MAX the latest generation of IMA HMI, created paying maximum attention to User Experience.

MAX HMI is based on KORTEX iFix SCADA, IoT ready. FLEX SERIES offers multiple control system platforms:

- **KORTEX Lite: recipe controls LLC/HMI system**
- **KORTEX: full recipe control suite system with Allen Bradley or Siemens PLC**



MAX HMI

MAX ensures prompt responsiveness, enhanced predictability and easy learning and facilitates connection with other equipment in solid-dose processing lines. Automatic recipes, reports and audit trails for processing or cleaning can be edited and managed to ensure maximum efficiency and consistent results in compliance with current directives and guidelines (ANSI/ISA-88, FDA CFR 21 part 11, GAMP®, MHRA GMP Data Integrity).

FLEX 05

THE FLEX 05 IS MORE THAN JUST A FILM COATER – IT IS A PRACTICAL AND HIGHLY FUNCTIONAL COATING PLATFORM FOR MOST PROCESSES INCLUDING THOSE WHERE HIGH WEIGHT-GAIN, DRUG LAYERS, AND MODIFIED RELEASE COATINGS ARE ESSENTIAL.

The FLEX 05 coater includes computer-based controls with data acquisition in a compact package featuring a color touch screen HMI. Convenient and versatile, the FLEX 05 is sure to become your indispensable coater for rapid product development, feasibility studies, and production of early stage clinical supplies – even with just a handful of tablets.



FUNCTIONALITY

- DRUM CAPACITY IS 5 LITERS
- FULLY PERFORATED DRUM WITH ANTI-SLIDE BARS
- SCHLICK™ SPRAY NOZZLE WITH ANTI-BEARDING CAP
- EXHAUST TEMPERATURE SET POINT CONTROL
- OPTIONAL INDEPENDENT CONTROL OF ATOMIZING AND PATTERN AIR
- EXTERNAL SPRAY NOZZLE POSITIONING WITH COATER DOOR CLOSED
- DIVIDER PLATES FOR SMALL BATCHES

USABILITY

- 24 X 36 INCH [610 MM X 815 MM] FOOTPRINT - FITS NEATLY ON STANDARD LABORATORY BENCH
- 10-INCH COLOR TOUCH SCREEN HMI
- FRONT ACCESS MANUAL SAMPLING
- EXCELLENT VISIBILITY THROUGH FRONT WINDOW
- EASY DISASSEMBLY FOR CLEANING AT THE BENCH OR OUT-OF-PLACE
- BENCHTOP OR CART-MOUNTED FOR MOBILE APPLICATIONS

INNOVATION

- COAT VERY SMALL QUANTITIES OF CORES — AS FEW AS 100 TABLETS
- OPTIONAL EXCHANGEABLE COATING UNIT WITH INTEGRATED COATING CHAMBER, DRUM, EXHAUST PLENUM AND PROCESS PORT AVAILABLE FOR CONTAINMENT
- COMPLETE SEPARATION OF PRODUCT CONTACT AREA FROM MECHANICAL SPACE
- CLOSED TRANSFERS FOR OFF-BENCH LOADING/ UNLOADING UNDER CONTAINMENT AVAILABLE WITH CONTAINMENT VERSION

VERSATILITY

- AQUEOUS AND OPTIONAL SOLVENT COATING PROCESSES
- FUNCTIONAL AND MODIFIED RELEASE COATINGS
- COATING WITH ONE OR MORE DRUG LAYERS
- TABLETS, MINITABLETS AND SOFTGELS
- OPTIONAL EXECUTION FOR HANDLING POTENT COMPOUNDS



ONE COATING PLATFORM - MANY USES

- FLEX 05 IS A COST EFFECTIVE ALTERNATIVE TO PURCHASING MULTIPLE CONVENTIONAL-TYPE LABORATORY COATING SYSTEMS
- NOZZLE POSITIONING MECHANISM WITH GRADUATED SCALE FOR REPEATABLE NOZZLE-TO-BED DISTANCE AND ANGLE SETTINGS
- PERISTALTIC PUMP WITH PRECISE FLOW CONTROL
- SCHLICK™ ANTI-BEARDING SPRAY NOZZLE

CONTAINMENT OPTION

- COATER OPERATES UNDER NEGATIVE PRESSURE
- INFLATABLE SEAL
- SANITARY FLANGES AVAILABLE FOR CLOSED LOADING AND UNLOADING
- MANUAL SAMPLING AND SPRAY NOZZLE POSITIONING WITH FRONT PROCESS PORT CLOSED
- FULLY CONTAINED EXECUTION WITH SAFE CHANGE FILTERS AVAILABLE

INNOVATIVE REMOVABLE COATING CHAMBER (XCU)

- FLEX 05 WITH OPTIONAL CONTAINMENT FEATURES EXCHANGEABLE COATING UNITS — DRUM, CHAMBER, PLENUM AND PROCESS PORT
- XCU IS SELF-CONNECTING TO THE INLET/EXHAUST AIR PORTS AND TO DRUM DRIVE
- EASY REMOVAL AND INSTALLATION FOR FAST SETUPS AND CHANGEOVERS WITHOUT TOOLS
- INTEGRATED EXHAUST PLENUM EXTRACTS WITH THE XCU FOR EASY CLEANING

FLEX 100

THE FLEX 100 IS A FULLY INTEGRATED,
RECIPE DRIVEN R&D/PILOT SCALE TABLET COATING
SYSTEM WITH EXCHANGEABLE DRUMS.



Designed to offer a wide variety of industry leading high-performance features, the Flex 100 features external gun positioning, auto unload, patented Thomas Spray Bar with Schlick patented ABC technology and 6 exchangeable drums allowing for capacity range of 2-125 Liters. The Flex 100 also comes with Wash-In-Place configurations and an optional containment version for use with highly potent products.



HIGH PERFORMANCE FEATURES

- SUITABLE FOR FILM, FUNCTIONAL, SUGAR AND DRUG LAYER COATING
- PATENTED THOMAS SPRAY BAR®
- EXTERNAL GUN POSITIONING
- AUTO UNLOAD
- EXCHANGEABLE DRUMS WITH 2-125 LITER CAPACITY RANGE
- WASH-IN-PLACE OPTIONS

INDUSTRY PROVEN FULLY PERFORATED DRUM DESIGN

- MAXIMUM COATING QUALITY
- MAXIMUM TABLET COATING EFFICIENCY
- IDEAL MIXING ACTION
- TURBULENCE-FREE AIR FLOW PATH

FLEX 200

THE THOMAS PROCESSING FLEX 200 IS A RECIPE DRIVEN PILOT / PRODUCTION SCALE TABLET COATING SYSTEM WITH EXCHANGEABLE DRUMS.



Designed to offer a wide variety of industry leading high-performance features, the Flex 200 features external gun positioning, auto unload, patented Thomas Spray Bar with Schlick ABC technology, and exchangeable drums allowing for capacity range of 30-325 liters. Thomas Processing Flex 200 also comes available with Wash-In-Place configurations and an optional containment version for use with highly potent products.

HIGH PERFORMANCE FEATURES

- THOMAS'S PATENTED EXCHANGEABLE DRUM FEATURE
- PATENTED THOMAS PROCESSING SPRAY BAR
- EXTERNAL GUN POSITIONING AUTO-UNLOAD
- EXCHANGEABLE DRUMS WITH 30-325 LITER CAPACITY RANGE
- WASH-IN-PLACE OPTIONS



THOMAS PATENTED DRUM EXCHANGE FEATURE

Continuing the history of innovation and technical advancement, the Flex 200 features a proprietary Thomas Processing drum exchange system. Designed to decrease the changeover time and improve cleanability.

The Thomas patented exchangeable drum design allows each coating drum to be easily removed and can be immediately exchanged with any of the four available drum configurations.

INDUSTRY PROVEN FULLY PERFORATED DRUM DESIGN

- MAXIMUM COATING QUALITY
- MAXIMUM TABLET COATING EFFICIENCY
- IDEAL MIXING ACTION
- TURBULENCE-FREE AIR FLOW PATH
- SUITABLE FOR FILM, FUNCTIONAL, SUGAR AND DRUG LAYER COATING

FLEX 500

THE THOMAS PROCESSING FLEX 500 IS A HIGHLY EFFICIENT TABLET COATING SYSTEM DESIGNED FOR THE SPECIAL NEEDS OF THE PHARMACEUTICAL INDUSTRY, WHICH FEATURES OUR PATENTED EXCHANGEABLE DRUM DESIGN.

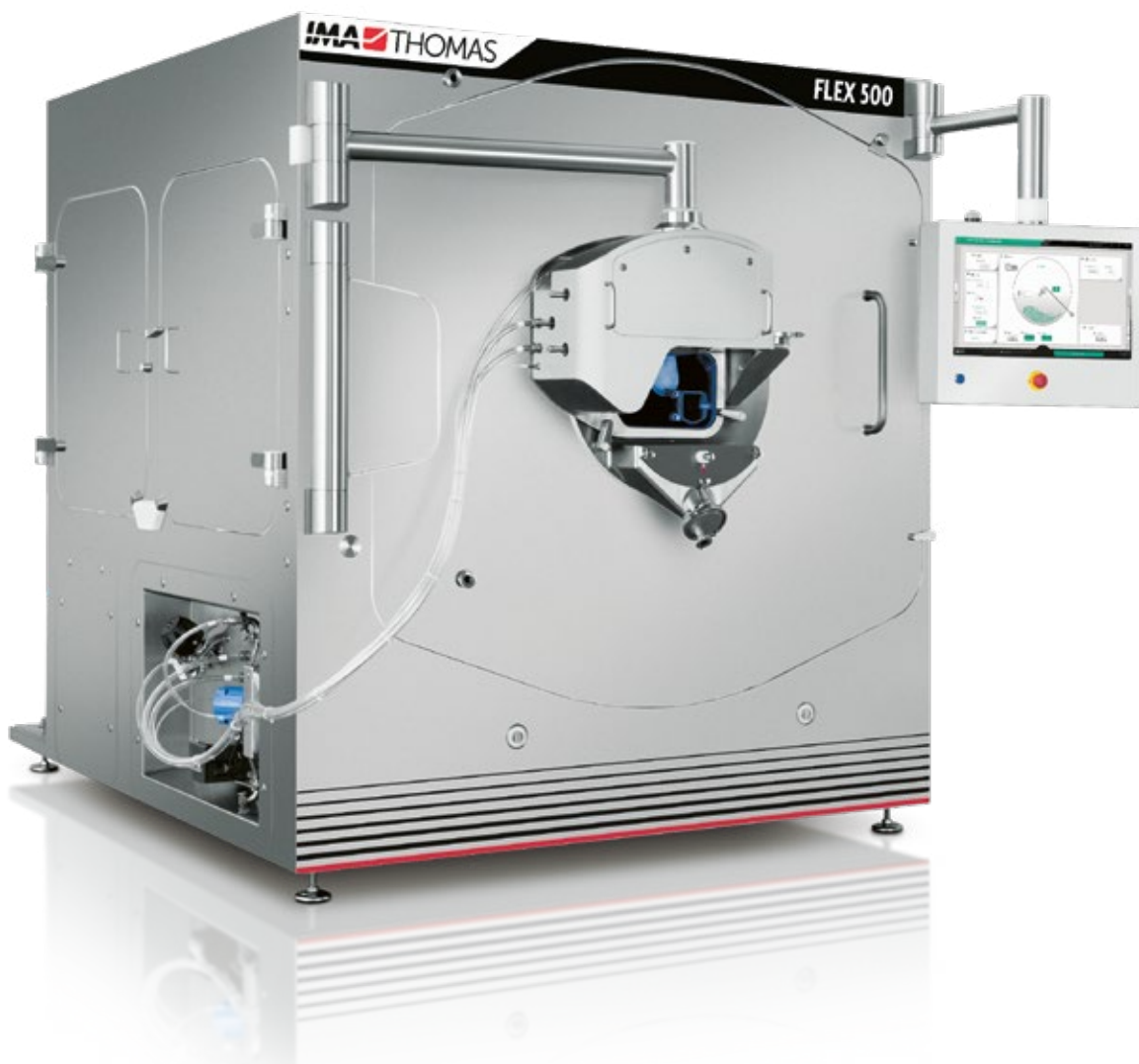

Standard configuration allows for all aqueous tablet coating processes including film, sugar, functional, and active multi-layer coatings. Optional features allow for organic solvent coating and various OEL containment levels for potent compound processing.

The Thomas patented exchangeable drum design allows each coating drum to be easily removed and can be immediately exchanged with any of the eight available drum configurations.



FLEXIBILITY

- 8 EXCHANGEABLE DRUM CONFIGURATIONS AVAILABLE
- PROCESS BATCH LOADS FROM 25% TO 100% OF DRUM CAPACITY
- DEDICATE DRUMS TO PRODUCT CLASSES OR TO CONTRACT MANUFACTURING CLIENTS
- EASY TO USE GRAPHIC HMI WITH MULTIPLE LANGUAGES
- ADAPT EASILY TO FUTURE NEEDS

INNOVATION

- ENHANCED COATER UTILIZATION
- REMOVABLE DRUM FOR INSPECTION AND CLEANING
- EXCHANGEABLE DRUMS FOR UNMATCHED FLEXIBILITY
- INTERCHANGEABLE MIXING BAFFLES
- PATENTED THOMAS SPRAY BAR

DRUM EXCHANGE

Thomas Processing is the originator of the fully perforated side-vented drum. Today, Thomas continues our legacy of imaginative and practical coater design with the FLEX 500. The compelling simplicity of the design makes routine drum exchange fast and easy.

- Choose a drum configuration and mixing baffles to best suit requirements of the process.
- Dedicate drums to specific drug compounds or to individual clients.
- Reduce risk of cross-contamination.
- Faster cleaning and product changeover for enhanced utilization.
- Reduce facility improvement costs and operating expenses - build and staff one coating suite for the FLEX 500 instead of two or more suites for ordinary tablet coaters.

FLEX 500

FLEXIBILITY

- ROUTINE EXCHANGE OF DRUMS WITHIN THE COATING SUITE
- WIDE TURNDOWN VOLUME OF 40 TO 920 LITERS IN SAME MACHINE - 8 DRUM SIZES AVAILABLE
- PROCESS BATCH LOADS FROM 25% TO 100% OF DRUM CAPACITY
- EXTERNALLY POSITION SPRAY BAR FOR OPTIMAL ANGLE AND DISTANCE TO BED
- EXCHANGEABLE MIXING BAFFLES
- INSTALL THROUGH-THE-WALL, FRONT OR REAR FLUSH, OR FREE STANDING
- ADAPT EASILY TO FUTURE MANUFACTURING NEEDS



SOLUTION DELIVERY

- PERISTALTIC PUMP WITH SINGLE OR DUAL ELEMENT HEAD
- RECIRCULATION TO REDUCE SETTLING OF SOLIDS IN SOLUTION LINES
- CHOICE OF VOLUMETRIC OR MASS FLOWMETER
- AUTOMATED SOLUTION SWITCHING





CLEANABILITY

- "TOTAL ACCESS" DESIGN FOR SWABBING AND ROUTINE INSPECTION
- OPTIMIZED CHAMBER DESIGN FOR ENHANCED CLEANABILITY
- CONTINUOUSLY WELDED INTERIOR WITH ROUNDED CORNERS
- SMOOTH CHAMBER SURFACE FINISHES THROUGHOUT
- WATER-TIGHT INFLATABLE SEALS ON ACCESS DOORS

INTEGRATED PERIPHERALS

- RANGE OF AFFORDABLE WIP EXECUTIONS
- SOLUTION PREPARATION EQUIPMENT AND DELIVERY TANKS
- OPTIONAL DEVICES FOR ASSISTED LOADING USING IBCs OR DRUMS
- PURPOSE-BUILT DOLLIES FOR DRUM EXCHANGE AND STORAGE

MIXING BAFFLES

- EXCHANGE AND SELECT BAFFLES TO BEST SUIT A PROCESS
- DESIGNED FOR TOOL-LESS REMOVAL AND ASSEMBLY
- CHOICE OF THOMAS HELICAL OR PLOW BAFFLES



TECHNICAL DATA

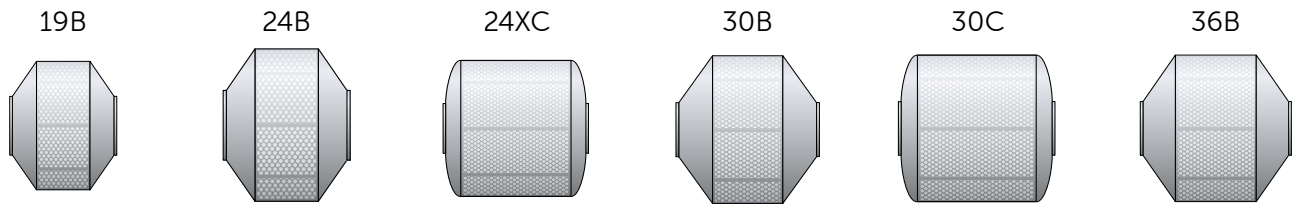

FLEX 100	19B	24B	24XC	30B	30C	36B
Drum diameter (")	19" (440 mm)	24" (610 mm)	24" (610 mm)	30" (760 mm)	30" (760 mm)	36" (915 mm)
Drum capacity (l)	8	25	75	75	125	110

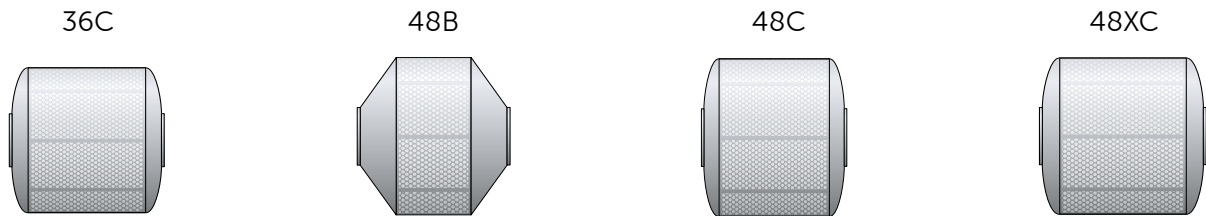

FLEX 200	36C	48B	48C	48XC
Drum diameter (")	36" (915 mm)	48" (1,220 mm)	48" (1,220 mm)	48" (1,220 mm)
Drum capacity (l)	110	190	250	325

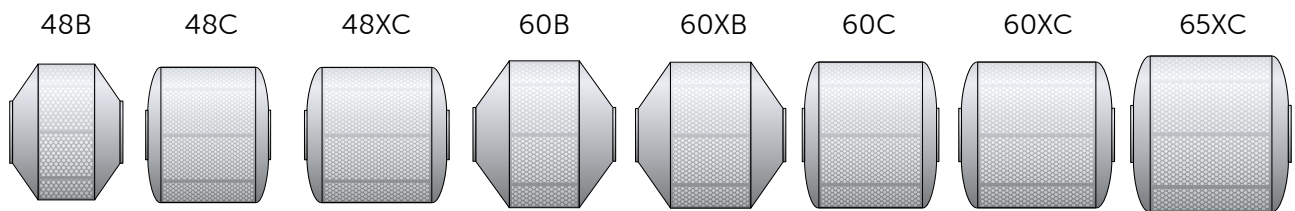

FLEX 500	48B	48C	48XC	60B	60XB	60C	60XC	65XC
Drum diameter (")	48" (1,220 mm)			60" (1,525 mm)				65" (1,650 mm)
Drum capacity (l)	190	250	325	460	530	530	750	920
Recommened airflow (cfm)	2,500 (4,250 m ³ /hr)			4,000 (6,800 m ³ /hr)				7,000 (12,000 m ³ /hr)
Width (")	60"			72"				
Height (")	80"			86"				
Depth (")	90"			100"				
Net weight (lbs)	4,125			5,500				

FLEX 05

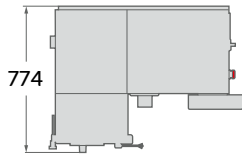
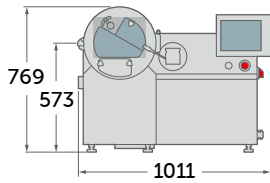

FLEX 100

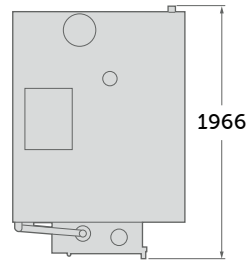
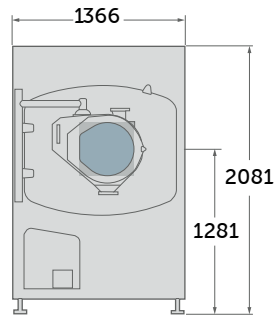

FLEX 200

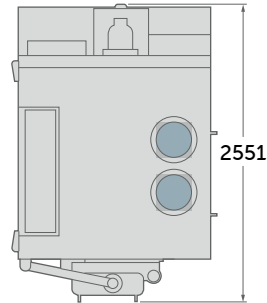
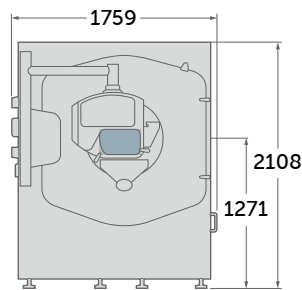

FLEX 500

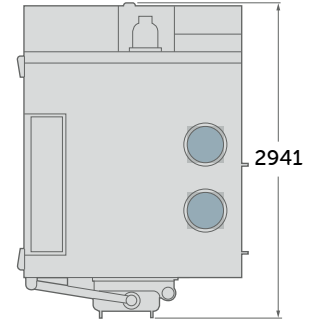
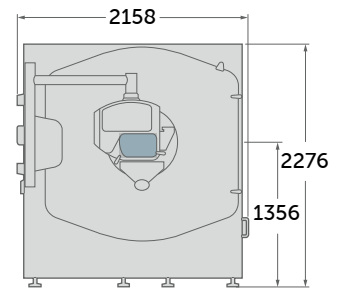

MODEL	FLEX 05	FLEX 100	FLEX 200	FLEX 500
Minimum/maximum capacity (l)	0.5-5 100 ml w/ divider plate	8 (2-8) 25 (8-25) 75 (15-75) 75 (25-75) 110 (30-110) 125 (25-125)	110 (30-110) 190 (40-190) 250 (50-250) 325 (80-325)	190 (40-190) 250 (50-250) 325 (80-325) 460 (100-460) 530 (120-530) 750 (175-750) 920 (230-920)
Drum diameter (")	12" (305mm)	19" (440) 24" (610) 24" (610) 30" (760) 30" (760) 36" (915)	36" (915) 48" (1,220) 48" (1,220) 48" (1,220)	48" (1,220) 48" (1,220) 48" (1,220) 60" (1,525) 60" (1,525) 60" (1,525) 65" (1,650)
Pan mouth diameter (")	11.5" (254)	10" (254) 16" (406)	19" (483)	
Process air delivery (cfm)	100 (170 m ³ /hr)	1,000 (1,700 m ³ /hr)	2,500 (4,250 m ³ /hr) 4,000 (6,800 m ³ /hr)	2,500 (4,250 m ³ /hr) 4,000 (6,800 m ³ /hr) 7,000 (11,900 m ³ /hr)

ima.it

IMA NORTH AMERICA INC. - THOMAS PROCESSING division
info@ima.it • thomasprocessing.com
FOLLOW IMA 